

**BUCG-06-\*\*-30/3080/3090**

Model Numbers	"A" Thd.	"B" Thd.
BUCG-06-**-30	Rc 1/4	Rc 1/4
BUCG-06-**-3080	1/4 BSP.Tr	1/4 BSP.F
BUCG-06-**-3090	1/4 NPT	1/4 NPT

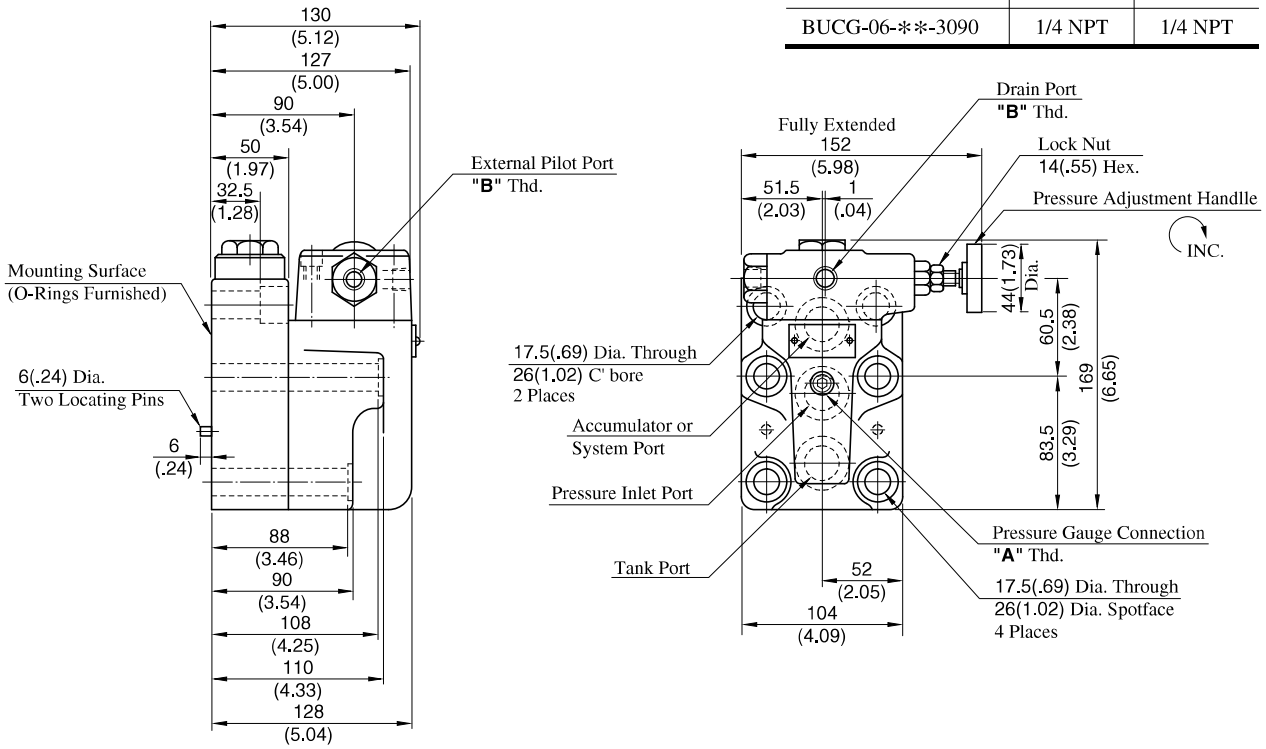

**DIMENSIONS IN MILLIMETRES (INCHES)**

**Sub-plate**

**BUCGM-06-20/2080/2090**

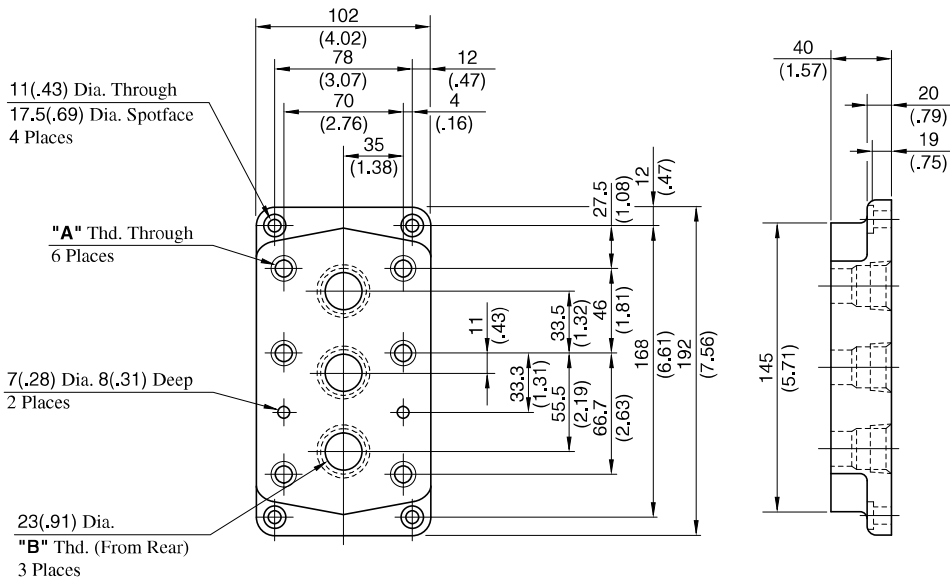

Sub-plate Model No.	"A" Thd.	"B" Thd.
BUCGM-06-20	M16	Rc 3/4
BUCGM-06-2080	M16	3/4 BSP.F
BUCGM-06-2090	5/8-11 UNC	3/4 NPT



**BUCG-10-\*\*-25/2580/2590**

Model Numbers	"A" Thd.	"B" Thd.
BUCG-10-**-25	Rc 1/4	Rc 1/4
BUCG-10-**-2580	1/4 BSP.Tr	1/4 BSP.F
BUCG-10-**-2590	1/4 NPT	1/4 NPT

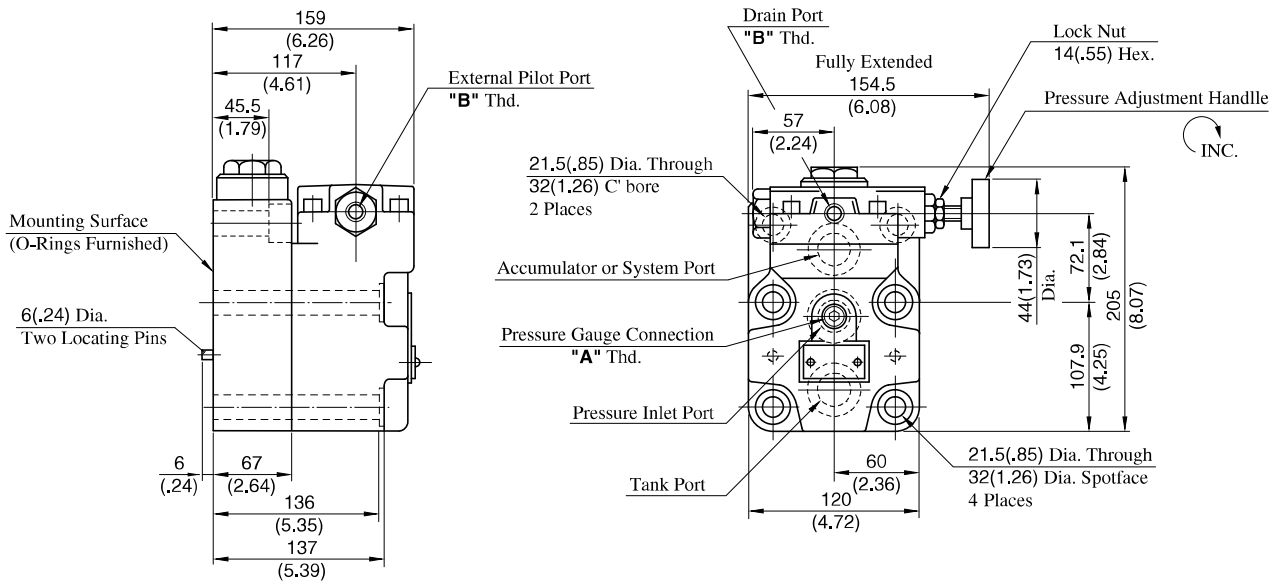

**DIMENSIONS IN MILLIMETRES (INCHES)**

**■ Sub-plate**

**BUCGM-10-20/2080/2090**

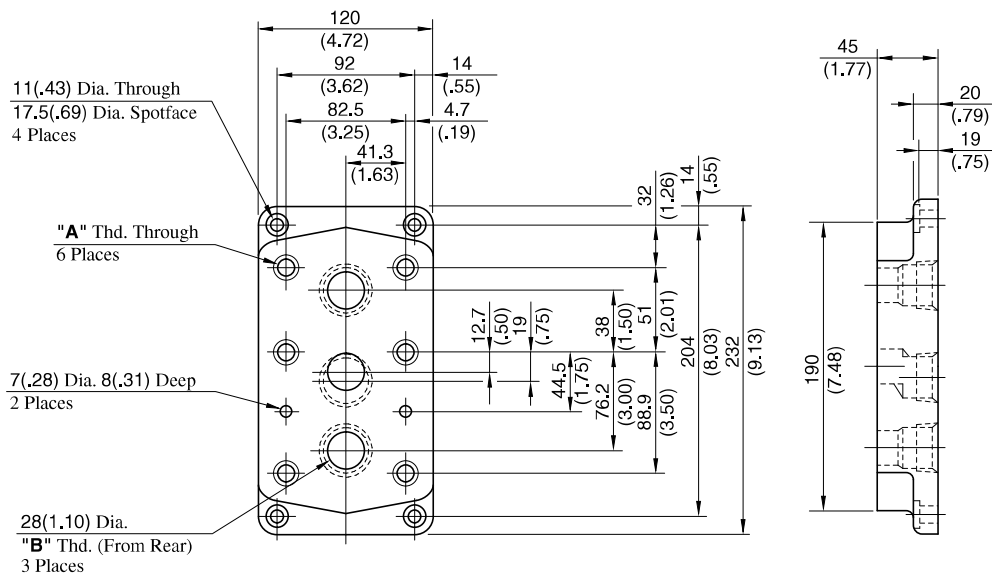

Sub-plate Model No.	"A" Thd.	"B" Thd.
BUCGM-10-20	M20	Rc 1-1/4
BUCGM-10-2080	M20	1-1/4 BSP.F
BUCGM-10-2090	3/4-10 UNC	1-1/4 NPT