

Check/Pilot Controlled Check Valves

Valve Type	Graphic Symbols	Max. Operating Pressure MPa (PSI)	Flow Rate										Page	
			U.S.GPM					L/min						
Check Valves		25 (3630)											498	
			In-Line (CIT)	02	03	06	10							
			Right Angle (CRT/CRG)		03	06	10							
			Right Angle, Flanged Connection (CRF)				10	16	24					
Pilot Operated Check Valves		25 (3630)											504	
			Threaded Connection(CP*T) Sub-plate Mounting(CP*G)	03	06	10								
			Flanged Connection(CP*F)				10	16						

In-Line Check Valves

These valves allow free flow in one direction and prevent flow in the reverse direction. Cracking pressure specified is the pressure required to open the valve and allow free flow.

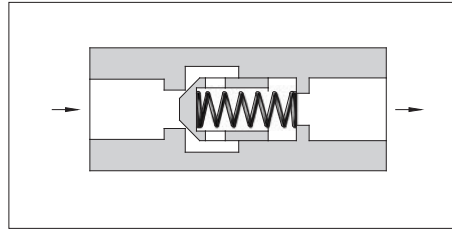

Graphic Symbol



Specifications

Model Numbers	Rated Flow* L/min (U.S.GPM)	Max. Operating Pres. MPa (PSI)	Cracking Pres. MPa (PSI)	Approx. Mass kg (lbs.)
CIT-02-* -50/5080/5090	16 (4.23)	25 (3630)	0.04 (6) 0.35 (50) 0.5 (70)	0.1 (.22)
CIT-03-* -50/5080/5090	30 (7.93)			0.3 (.66)
CIT-06-* -50/5080/5090	85 (22.5)			0.8 (1.8)
CIT-10-* -50/5080/5090	230 (60.8)			2.3 (5.1)

★ Rated flow is the approximate flow rate, when there is a free flow pressure drop of maximum 0.3 MPa (44 PSI), the fluid has a specific gravity of 0.85 and a kinematic viscosity of 20 mm²/s (98 SSU), and the cracking pressure is 0.04 MPa (6 PSI).

Model Number Designation

CI	T	-03	-04	-50	*
Series Number	Type of Connection	Valve Size	Cracking Pressure MPa (PSI)	Design Number	Design Standards
CI: In-Line Check Valve	T: Threaded Connection	02	04: 0.04 (6) 35: 0.35 (50) 50: 0.5 (70)	50	None: Japanese Std. "JIS" 80: European Design Std. 90: N. American Design Std.
		03		50	
		06		50	
		10		50	

Note: For In-Line Check Valves, standard type (for petroleum base oils) can be used phosphate ester type fluid.

CIT-02-* -50/5080/5090
CIT-03-* -50/5080/5090
CIT-06-* -50/5080/5090
CIT-10-* -50/5080/5090

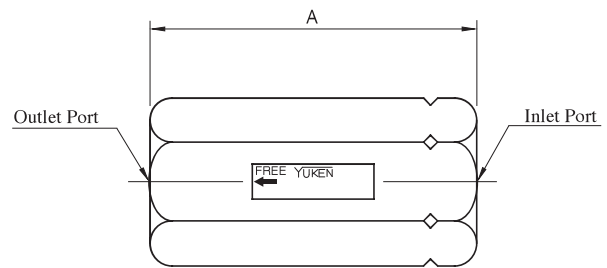
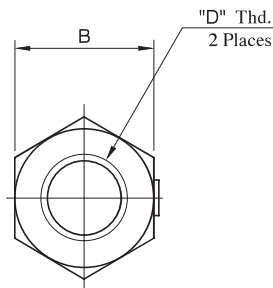

Model Numbers	mm (Inches)		"D" Thd.
	A	B	
CIT-02-* -50	58 (2.28)	19 (.75)	Rc 1/4
CIT-02-* -5080	65 (2.56)	22 (.87)	1/4 BSP.F
CIT-02-* -5090	58 (2.28)	19 (.75)	1/4 NPT
CIT-03-* -50	76 (2.99)	27 (1.06)	Rc 3/8
CIT-03-* -5080	83 (3.27)		3/8 BSP.F
CIT-03-* -5090	76 (2.99)		3/8 NPT
CIT-06-* -50	95 (3.74)	41 (1.61)	Rc 3/4
CIT-06-* -5080	102 (4.02)		3/4 BSP.F
CIT-06-* -5090	95 (3.74)		3/4 NPT
CIT-10-* -50	133 (5.24)	60 (2.36)	Rc 1-1/4
CIT-10-* -5080			1-1/4 BSP.F
CIT-10-* -5090			1-1/4 NPT

DIMENSIONS IN MILLIMETRES (INCHES)

Pressure Drop

Hydraulic Fluid: Viscosity 30 mm²/s (141 SSU), Specific Gravity 0.850

CIT-02

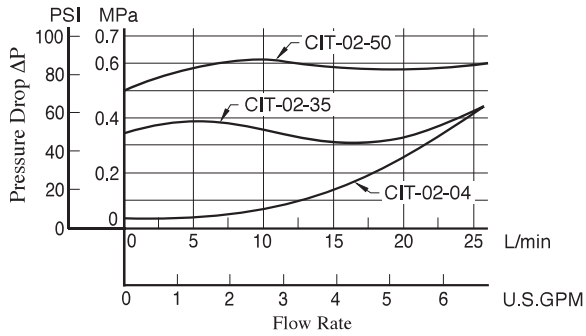

CIT-03

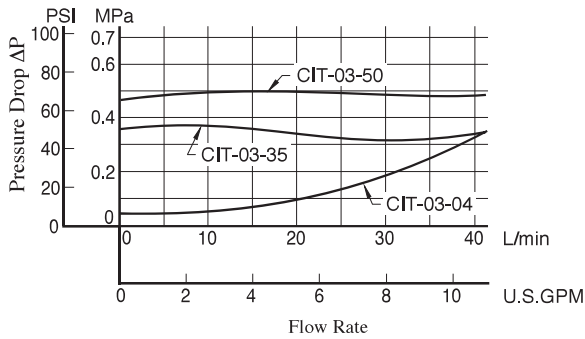

CIT-06

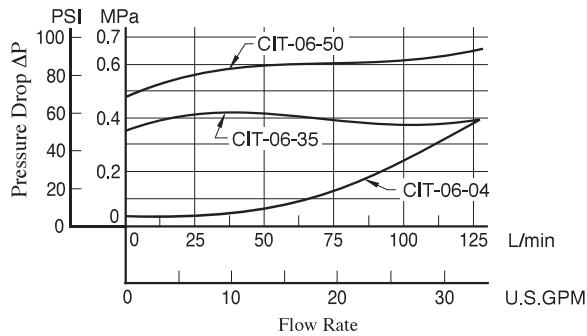

CIT-10

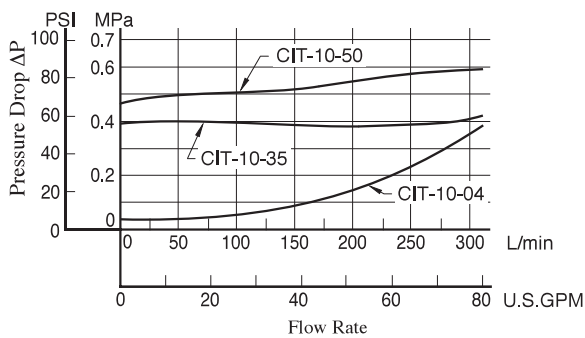

Right Angle Check Valves

These valves allow free flow in one direction and prevent flow in the reverse direction. Cracking pressure specified is the pressure required to open the valve and allow free flow.

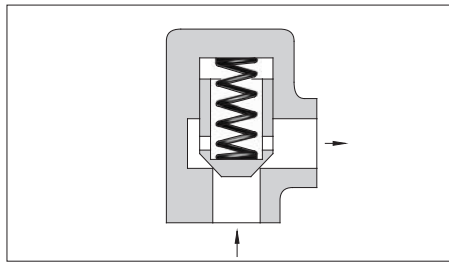

Graphic Symbol

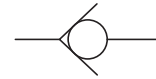

Specifications

Type of Connection	Model Numbers	Rated Flow* L/min (U.S.GPM)	Max. Operating Pres. MPa (PSI)	Cracking Pres. MPa (PSI)	Approx. Mass kg (lbs.)
Threaded Connection	CRT-03-* -50/5080/5090	40 (10.6)	25 (3630)	0.04 (6)	0.9 (2.0)
	CRT-06-* -50/5080/5090	125 (33)		0.35 (50)	1.7 (3.7)
	CRT-10-* -50/5080/5090	250 (66)		0.5 (70)	5.6 (12.3)
Sub-plate Mounting	CRG-03-* -50/5090	40 (10.6)	25 (3630)	0.04 (6)	1.7 (3.7)
	CRG-06-* -50/5090	125 (33)		0.35 (50)	2.9 (6.4)
	CRG-10-* -50/5090	250 (66)		0.5 (70)	5.5 (12.1)

* Rated flow is the approximate flow rate, when there is a free flow pressure drop of maximum 0.3 MPa (44 PSI), the fluid has a specific gravity of 0.85 and a kinematic viscosity of 20 mm²/s (98 SSU), and the cracking pressure is 0.04 MPa (6 PSI).

Model Number Designation

F-	CR	T	-03	-04	-50	*
Special Seals	Series Number	Type of Connection	Valve Size	Cracking Pressure MPa (PSI)	Design Number	Design Standards
F: Special seals for phosphate ester type fluids (Omit if not required)	CR: Right Angle Check Valve	T: Threaded Connection	03	04: 0.04 (6)	50	None: Japanese Std. "JIS" 80: European Design Std. 90: N. American Design Std.
			06	35: 0.35 (50)	50	
			10	50: 0.5 (70)	50	
		G: Sub-plate Mounting	03	04: 0.04 (6)	50	None: Japanese Std. "JIS" & European Design Std. 90: N. American Design Std.
			06	35: 0.35 (50)	50	
			10	50: 0.5 (70)	50	

Sub-plate

Valve Model Numbers	Japanese Standard "JIS"		European Design Standard		N.American Design Standard		Approx. Mass kg (lbs.)
	Sub-plate Model Numbers	Thread Size	Sub-plate Model Numbers	Thread Size	Sub-plate Model Numbers	Thread Size	
CRG-03	CRGM-03-50	Rc 3/8	CRGM-03-5080	3/8 BSP.F	CRGM-03-5090	3/8 NPT	1.6 (3.5)
	CRGM-03X-50	Rc 1/2	CRGM-03X-5080	1/2 BSP.F	CRGM-03X-5090	1/2 NPT	1.6 (3.5)
CRG-06	CRGM-06-50	Rc 3/4	CRGM-06-5080	3/4 BSP.F	CRGM-06-5090	3/4 NPT	2.4 (5.3)
	CRGM-06X-50	Rc 1	CRGM-06X-5080	1 BSP.F	CRGM-06X-5090	1 NPT	3.0 (6.6)
CRG-10	CRGM-10-50	Rc 1-1/4	CRGM-10-5080	1-1/4 BSP.F	CRGM-10-5090	1-1/4 NPT	4.8 (10.6)
	CRGM-10X-50	Rc 1-1/2	CRGM-10X-5080	1-1/2 BSP.F	CRGM-10X-5090	1-1/2 NPT	5.7 (12.6)

● Sub-plates are available. Specify the sub-plate model number from the table above. When sub-plates are not used, the mounting surface should have a good machined finish.

Yuken can offer flanged connection valves described below. For details, contact us.

Model No.	Rated Flow L/min (U.S.GPM)	Max. Operating Pressure MPa (PSI)
CRF-10-* -50*	300 (79.3)	25 (3630)
CRF-16-* -50*	600 (159)	
CRF-24-* -50*	1300 (343)	

Mounting Bolts

Socket head cap screws in the table below are included.

Valve Model Numbers	Socket Head Cap Screw		Qty.
	Japanese Standard "JIS" European Design Standard	N.American Design Standard	
CRG-03	M10 × 45 Lg.	3/8-16 UNC × 1-3/4 Lg.	4
CRG-06	M10 × 50 Lg.	3/8-16 UNC × 2 Lg.	4
CRG-10	M10 × 55 Lg.	3/8-16 UNC × 2-1/4 Lg.	6

CRT-03-* -50/5080/5090
 CRT-06-* -50/5080/5090
 CRT-10-* -50/5080/5090

DIMENSIONS IN MILLIMETRES (INCHES)

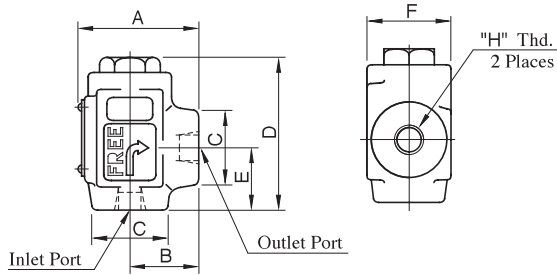

Model Numbers	Dimensions mm (Inches)						"H" Thd.
	A	B	C	D	E	F	
CRT-03-* -50	62	36	38	80.5	33	44	Rc 3/8
CRT-03-* -5080	(2.44)	(1.42)	(1.50) Dia	(3.17)	(1.30)	(1.73)	3/8 BSP.F
CRT-03-* -5090							3/8 NPT
CRT-06-* -50	74	45	54	104.5	49	54	Rc 3/4
CRT-06-* -5080	(2.91)	(1.77)	(2.13) Dia	(4.11)	(1.93)	(2.13)	3/4 BSP.F
CRT-06-* -5090							3/4 NPT
CRT-10-* -50	107	65	80	130	65	80	Rc 1-1/4
CRT-10-* -5080	(4.21)	(2.56)	(3.15) SQ.	(5.12)	(2.56)	(3.15)	1-1/4 BSP.F
CRT-10-* -5090							1-1/4 NPT

CRG-03-* -50/5090
 CRG-06-* -50/5090

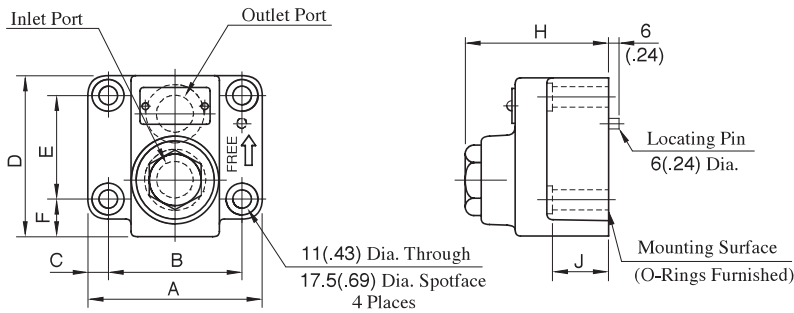

Model Numbers	Dimensions mm (Inches)								Mounting Surface
	A	B	C	D	E	F	H	J	
CRG-03	90	66.7	11.7	72	42.9	17.5	72.5	30	ISO 5781-AG-06-2-A
	(3.54)	(2.63)	(.46)	(2.83)	(1.69)	(.69)	(2.85)	(1.18)	
CRG-06	102	79.4	11.3	93	60.3	21.4	84.5	35	ISO 5781-AH-08-2-A
	(4.02)	(3.13)	(.44)	(3.66)	(2.37)	(.84)	(3.33)	(1.38)	

CRG-10-* -50/5090

Mounting surface: ISO 5781-AJ-10-2-A

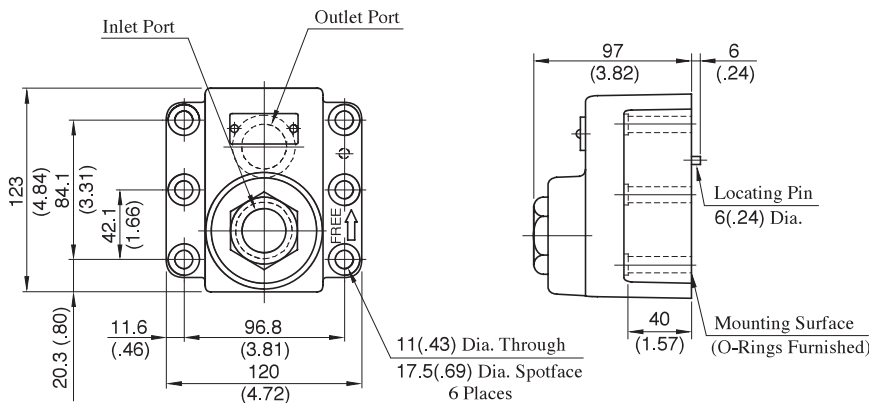

Sub-plate

CRGM-03-50/5080/5090
CRGM-03X-50/5080/5090

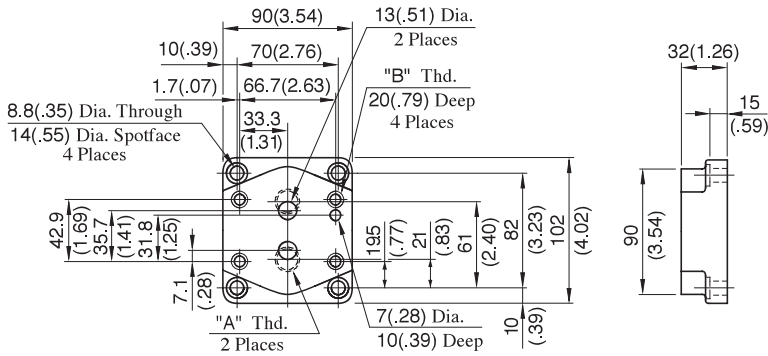

Sub-plate Model Numbers	Thread Size	
	"A" Thd.	"B" Thd.
CRGM-03-50	Rc 3/8	M10
CRGM-03-5080	3/8 BSP.F	
CRGM-03-5090	3/8 NPT	3/8-16 UNC
CRGM-03X-50	Rc 1/2	M10
CRGM-03X-5080	1/2 BSP.F	
CRGM-03X-5090	1/2 NPT	3/8-16 UNC

DIMENSIONS IN MILLIMETRES (INCHES)

CRGM-06-50/5080/5090
CRGM-06X-50/5080/5090

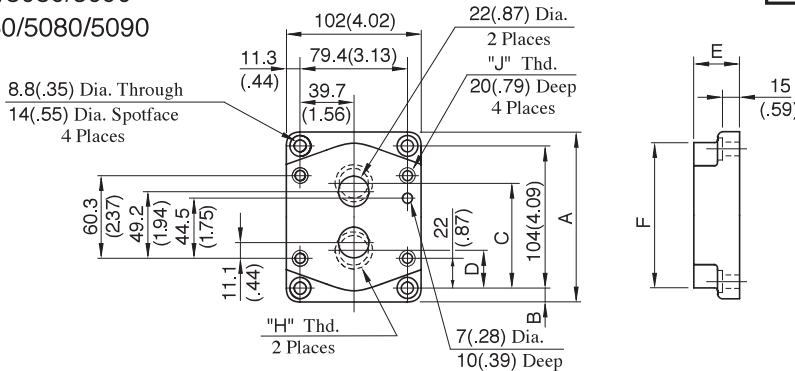

Sub-plate Model Numbers	Dimensions mm (Inches)						Thread Size	
	A	B	C	D	E	F	"H" Thd.	"J" Thd.
CRGM-06-50							Rc 3/4	M10
CRGM-06-5080	124 (4.88)	10 (.39)	77 (3.03)	27 (1.06)	36 (1.42)	110 (4.33)	3/4 BSP.F	
CRGM-06-5090							3/4 NPT	3/8-16 UNC
CRGM-06X-50			82.3 (3.24)	22 (.87)			Rc 1	M10
CRGM-06X-5080	136 (5.35)	16 (.63)	80 (3.15)	24 (.94)	45 (1.77)	130 (5.12)	1 BSP.F	
CRGM-06X-5090			82.3 (3.24)	22 (.87)			1 NPT	3/8-16 UNC

CRGM-10-50/5080/5090
CRGM-10X-50/5080/5090

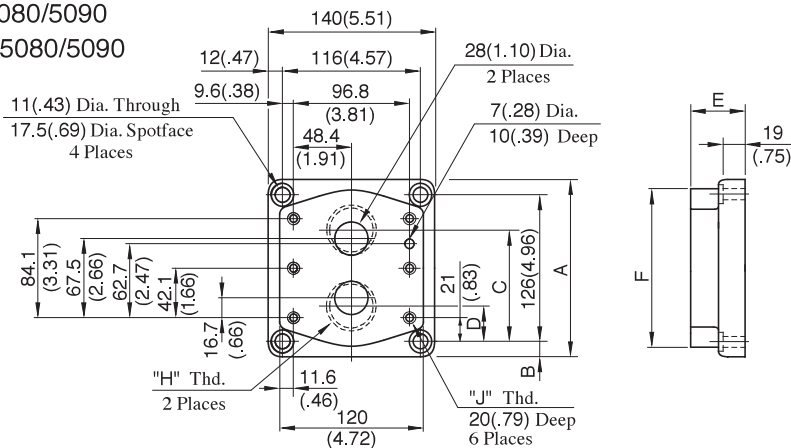

Sub-plate Model Numbers	Dimensions mm (Inches)						Thread Size	
	A	B	C	D	E	F	"H" Thd.	"J" Thd.
CRGM-10-50							Rc 1-1/4	M10
CRGM-10-5080	150 (5.91)	12 (.47)	96 (3.78)	30 (1.18)	45 (1.77)	135 (5.31)	1-1/4 BSP.F	
CRGM-10-5090							1-1/4 NPT	3/8-16 UNC
CRGM-10X-50							Rc 1-1/2	M10
CRGM-10X-5080	177 (6.97)	25.5 (1.00)	104 (4.09)	22 (.87)	50 (1.97)	167 (6.57)	1-1/2 BSP.F	
CRGM-10X-5090							1-1/2 NPT	3/8-16 UNC

Pressure Drop

Hydraulic Fluid: Viscosity 30mm²/s (141 SSU), Specific Gravity 0.850

● CRT-03

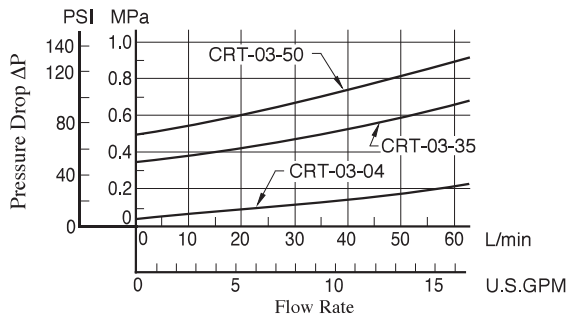

● CRG-03

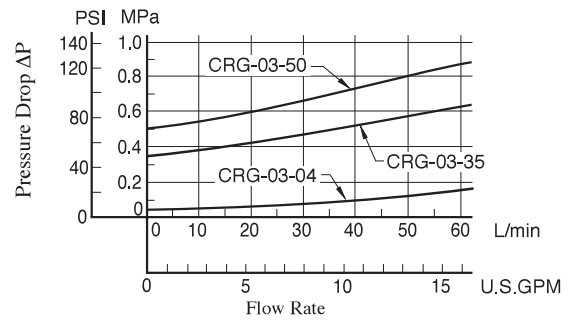

● CRT-06

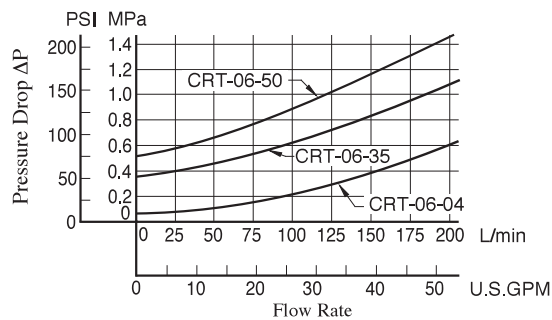

● CRG-06

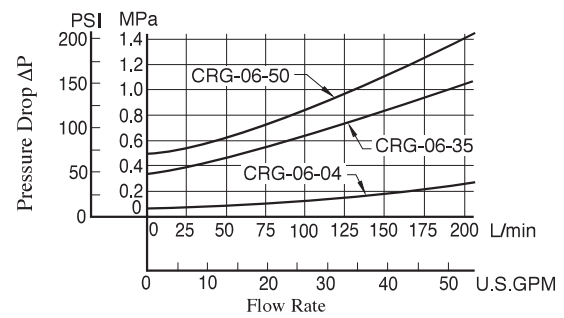

● CRT-10

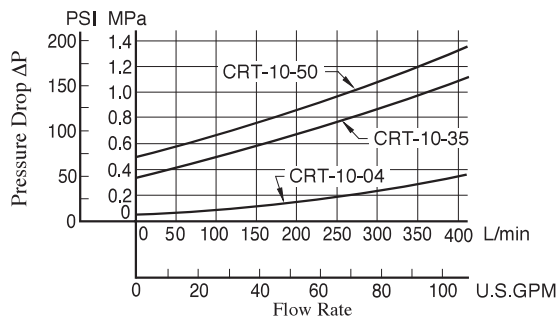

● CRG-10

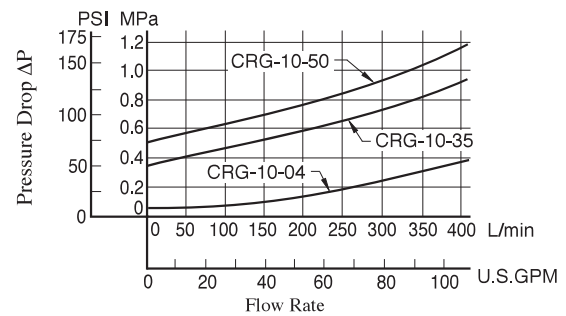

List of Seals

CRT-03-50/5080/5090
 CRT-06-50/5080/5090
 CRT-10-50/5080/5090

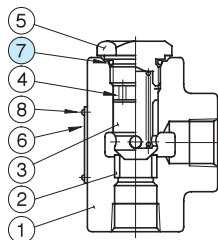

CRG-03-50/5090
 CRG-06-50/5090
 CRG-10-50/5090

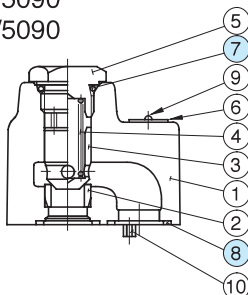

● List of Seals & Seal Kits

Item	Name of Parts	Part Numbers			Qty.
		CRT-03	CRT-06	CRT-10	
7	O-Ring	SO-NB-P21	SO-NB-P24	SO-NB-P32	1
★	Seal Kit	KS-CRT-03-50	KS-CRT-06-50	KS-CRT-10-50	—

★ When ordering the O-Rings, please specify the seal kit number from the table above.

● List of Seals & Seal Kits

Item	Name of Parts	Part Numbers			Qty.
		CRG-03	CRG-06	CRG-10	
7	O-Ring	SO-NB-P21	SO-NB-P24	SO-NB-P32	1
8	O-Ring	SO-NB-P18	SO-NB-P28	SO-NB-P32	2
★	Seal Kit	KS-CRG-03-50	KS-CRG-06-50	KS-CRG-10-50	—

★ When ordering the O-Rings, please specify the seal kit number from the table above.

Pilot Operated Check Valves

These check valves allow flow in one direction and prevent flow in the reverse direction, until operated by pilot pressure to allow free reverse flow. The specified cracking pressure is required to open the valve to allow free flow direction.

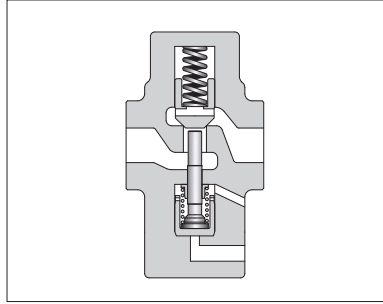

Graphic Symbols

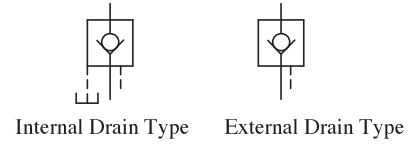

Specifications

Type of Connection	Model Numbers	Rated Flow* L/min (U.S.GPM)	Max. Operating Pres. MPa (PSI)	Cracking Pres. MPa (PSI)	Approx. Mass kg (lbs.)
Threaded Connection	CPT/CPDT-03-*-50*	40 (10.6)	25 (3630)	0.04 (6)	3.0 (6.6)
	CPT/CPDT-06-*-50*	125 (33)		0.2 (29)	5.5 (12.1)
	CPT/CPDT-10-*-50*	250 (66)		0.35 (50)	9.6 (21.2)
Sub-plate Mounting	CPG/CPDG-03-*-50*	40 (10.6)	25 (3630)	0.04 (6)	3.3 (7.3)
	CPG/CPDG-06-*-50*	125 (33)		0.2 (29)	5.4 (11.9)
	CPG/CPDG-10-*-50*	250 (66)		0.35 (50)	8.5 (18.7)

* Rated flow is the approximate flow rate, when there is a free flow pressure drop of maximum 0.3 MPa (44 PSI), the fluid has a specific gravity of 0.85 and a kinematic viscosity of 20 mm²/s (98 SSU), and the cracking pressure is 0.04 MPa (6 PSI).

Model Number Designation

F-	CP	T	03	-E	-04	-50	*
Special Seals	Series Number	Type of Connection	Valve Size	Drain Connection	Cracking Pres. MPa (PSI)	Design Number	Design Standards
F: Special Seals for Phosphate Ester Type Fluids (Omit if not required)	CP: Pilot Operated Check Valve	T: Threaded Connection	03	None: Internal Drain	04: 0.04 (6)	50	None: Japanese Std. "JIS" 80: European Design Std. 90: N. American Design Std.
			06			50	
			10			50	
	CPD: Decompression Type Pilot Operated Check Valve	G: Sub-plate Mounting	03	E: External Drain	35: 0.35 (50) 50: 0.5 (70)	50	None: Japanese Std. "JIS" & European Design Std. 90: N. American Design Std.
			06			50	
			10			50	

Mounting Bolts

Socket head cap screws in the table below are included.

Valve Model Numbers	Socket Head Cap Screw		Qty.
	Japanese Standard "JIS" & European Design Standard	N.American Design Standard	
CP*G-03	M10 × 45 Lg.	3/8-16 UNC × 1-3/4 Lg.	4
CP*G-06	M10 × 50 Lg.	3/8-16 UNC × 2 Lg.	4
CP*G-10	M10 × 55 Lg.	3/8-16 UNC × 2-1/4 Lg.	6

Yuken can offer flanged connection valves described below.
For details, contact us.

Model Numbers	Rated Flow L/min (U.S.GPM)	Max. Operating Pressure MPa (PSI)
CP*F-10-*-50*	250 (66)	25 (3630)
CP*F-16-*-50*	600 (159)	25 (3630)

Sub-plate

Valve Model Numbers	Japanese Standard "JIS"		European Design Standard		N. American Design Standard		Approx. Mass kg (lbs.)
	Sub-plate Model Numbers	Thread Size	Sub-plate Model Numbers	Thread Size	Sub-plate Model Numbers	Thread Size	
CP*G-03	HGM-03-20	Rc 3/8	HGM-03-2080	3/8 BSP.F	HGM-03-2090	3/8 NPT	1.6 (3.5)
	HGM-03X-20	Rc1/2	HGM-03X-2080	1/2 BSP.F	HGM-03X-2090	1/2 NPT	1.6 (3.5)
CP*G-06	HGM-06-20	Rc 3/4	HGM-06-2080	3/4 BSP.F	HGM-06-2090	3/4 NPT	2.4 (5.3)
	HGM-06X-20	Rc 1	HGM-06X-2080	1 BSP.F	HGM-06X-2090	1 NPT	3.0 (6.6)
CP*G-10	HGM-10-20	Rc 1-1/4	HGM-10-2080	1-1/4 BSP.F	HGM-10-2090	1-1/4 NPT	4.8 (10.6)
	HGM-10X-20	Rc 1-1/2	HGM-10X-2080	1-1/2 BSP.F	HGM-10X-2090	1-1/2 NPT	5.7 (12.6)

- Sub-plates are available, specify the sub-plate model number from the table above. When sub-plates are not used, the mounting surface should have a good machined finish.
- Sub-plates are shared with those for H Type Pressure Control Valves. Refer to [pages 244 to 246](#) for dimensions.

Instructions

Operation of internal and external drain types

When the outlet side P1 is directly connected to the tank in reversed free flow (Fig. a), the internal drain type is normally used. When the back pressure is applied to the outlet side P1 (Fig. b), be sure to use the external drain type.

Minimum pilot pressure characteristics

That depends on the pressure of the inlet side P2 in the reversed free flow.

This value can be determined from the characteristics chart.

Caution on replacement of 20 design low cracking pressure type valves with 50 design valves.

In 20 design valve with cracking pressure of 0.035 MPa (5 PSI) (Code "5"), for closing the valve completely and certainly, it was necessary to introduce the pressurized oil into the drain port to push down the piston compulsory.

While in 50 design valve with cracking pressure of 0.04 MPa (6 PSI) (Code "6"), it has such structure that the valve can be closed completely and certainly without introducing the pressurized oil into the drain port. On the contrary, what is worse is that if the pressurized oil is introduced into the drain port, the oil acts towards the direction of opening the valve, which is very dangerous and has to be absolutely avoided. Therefore, please do not supply any pressurized oil into the drain port in case of using 50 design valve.

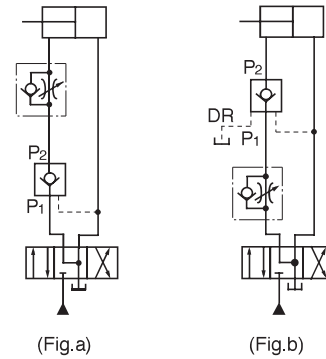

WARNING

The machinery, if misused due to failure to observe the "Cautions" on the left, may perform unforeseeable movements, resulting in a disastrous accident.

CPT/CPDT-03-**-**-50/5080/5090
 CPT/CPDT-06-**-**-50/5080/5090
 CPT/CPDT-10-**-**-50/5080/5090

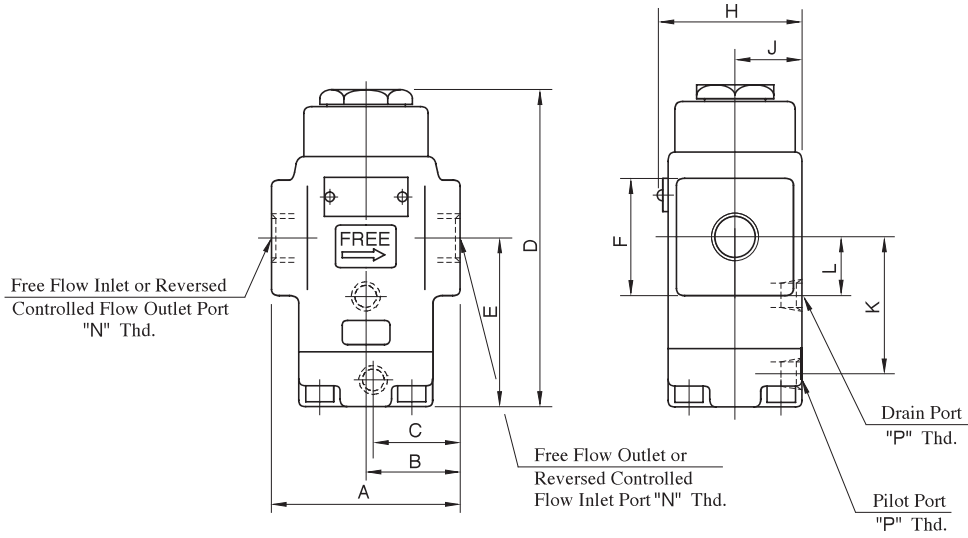

Model Numbers	Dimensions mm (Inches)										Thread Size	
	A	B	C	D	E	F	H	J	K	L	"N" Thd.	"P" Thd.
CPT/CPDT-03-**-**-50											Rc 3/8	Rc 1/4
CPT/CPDT-03-**-**-5080	80 (3.15)	40 (1.57)	39 (1.54)	150.5 (5.93)	84.5 (3.33)	38 (1.50) Dia.	60 (2.36)	29 (1.14)	67.5 (2.66)	26.5 (1.04)	3/8 BSP.F	1/4 BSP.F
CPT/CPDT-03-**-**-5090											3/8 NPT	1/4 NPT
CPT/CPDT-06-**-**-50											Rc 3/4	Rc 1/4
CPT/CPDT-06-**-**-5080	96 (3.78)	48 (1.89)	47 (1.85)	171.5 (6.75)	92.5 (3.64)	62 (2.44) SQ.	72 (2.83)	35 (1.38)	75.5 (2.97)	31 (1.22)	3/4 BSP.F	1/4 BSP.F
CPT/CPDT-06-**-**-5090											3/4 NPT	1/4 NPT
CPT/CPDT-10-**-**-50											Rc 1-1/4	Rc 1/4
CPT/CPDT-10-**-**-5080	140 (5.51)	70 (2.76)	64 (2.52)	203.5 (8.01)	113 (4.45)	80 (3.15) SQ.	82 (3.23)	40 (1.57)	96 (3.78)	43 (1.69)	1-1/4 BSP.F	1/4 BSP.F
CPT/CPDT-10-**-**-5090											1-1/4 NPT	1/4 NPT

CPG/CPDG-03-**-50/5090
 CPG/CPDG-06-**-50/5090

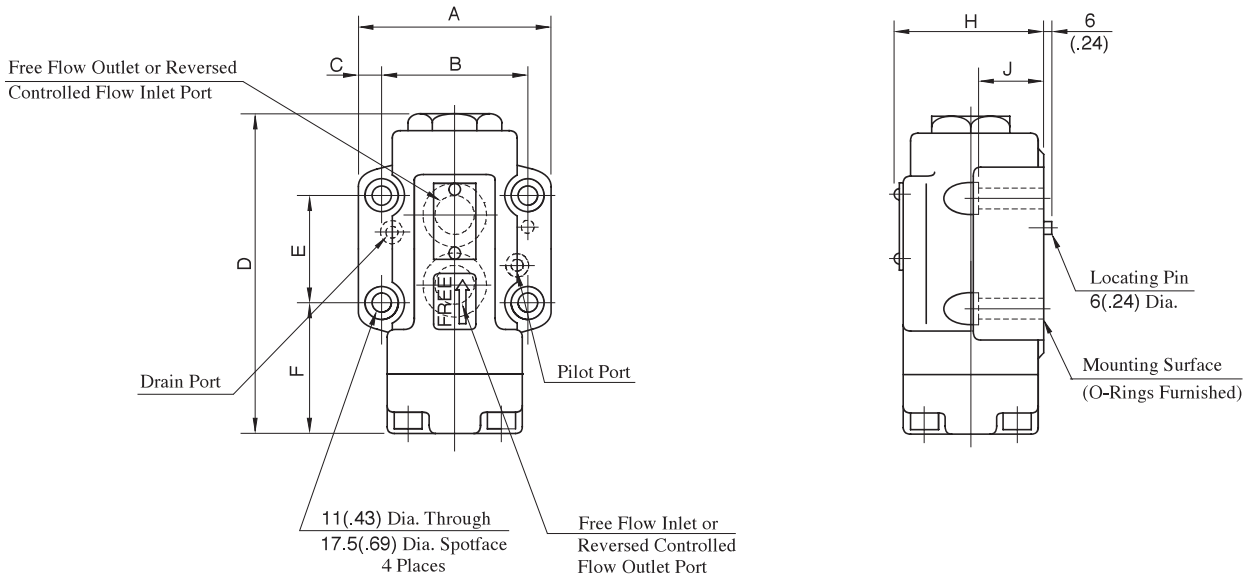

Model Numbers	Dimensions mm (Inches)								Mounting Surface
	A	B	C	D	E	F	H	J	
CPG/CPDG-03-**-50/5090	90 (3.54)	66.7 (2.63)	11.7 (.46)	150.5 (5.93)	42.9 (1.69)	66 (2.60)	62 (2.44)	30 (1.18)	ISO 5781-AG-06-2-A
CPG/CPDG-06-**-50/5090	102 (4.02)	79.4 (3.13)	11.3 (.44)	171.5 (6.75)	60.3 (2.37)	67.5 (2.66)	74 (2.91)	35 (1.38)	ISO 5781-AH-08-2-A

CPG/CPDG-10-**-50/5090

Mounting surface: ISO 5781-AJ-10-2-A

DIMENSIONS IN MILLIMETRES (INCHES)

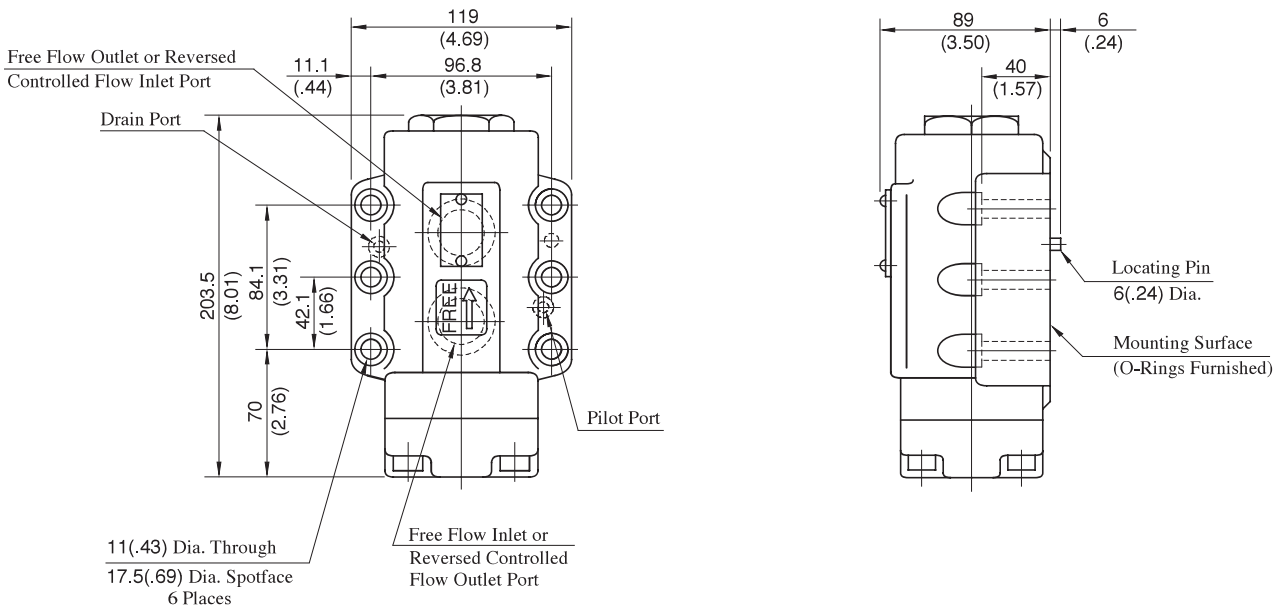

Hydraulic Fluid: Viscosity 30 mm²/s (141 SSU), Specific Gravity 0.850

Pressure Drop

● CPT-03, CPDT-03

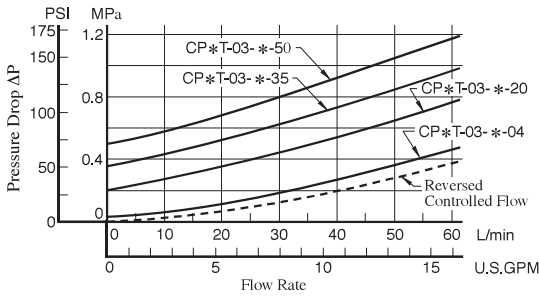

● CPG-03, CPDG-03

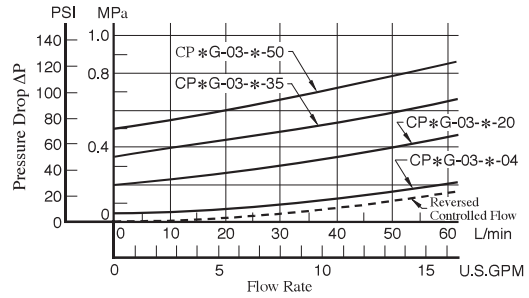

● CPT-06, CPDT-06

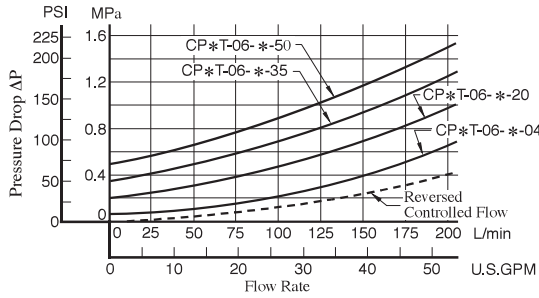

● CPG-06, CPDG-06

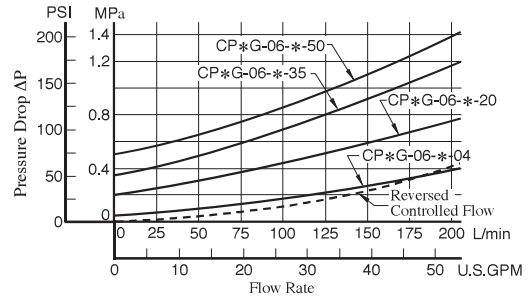

● CPT-10, CPDT-10

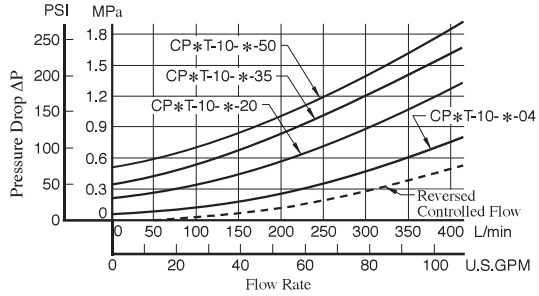

● CPG-10, CPDG-10

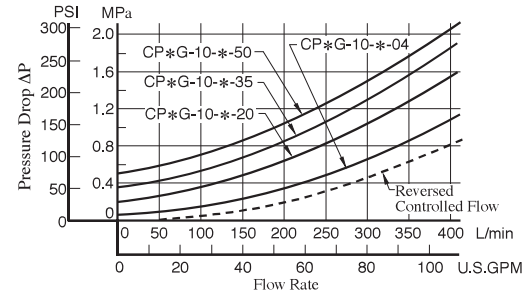

Min. Pilot Pressure Chart

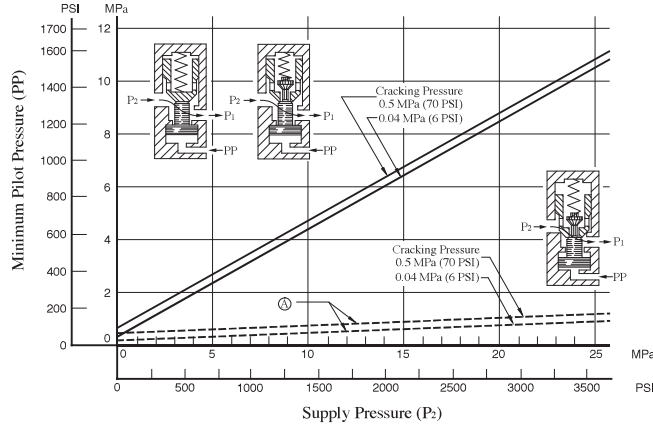

Ⓐ : Min. Pilot Pressure to open the Decompression Valve

Pressure Drop for Reversed Controlled Flow Only when Decompression Valve is Opened

● CPDT-03, CPDG-03

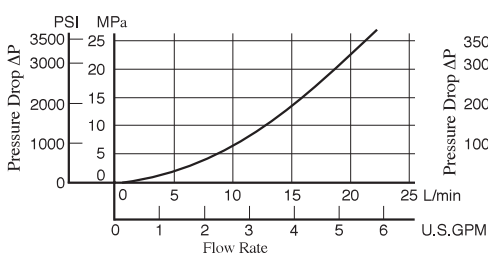

● CPDT-06, CPDG-06

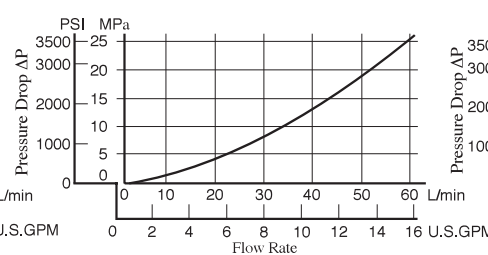

● CPDT-10, CPDG-10

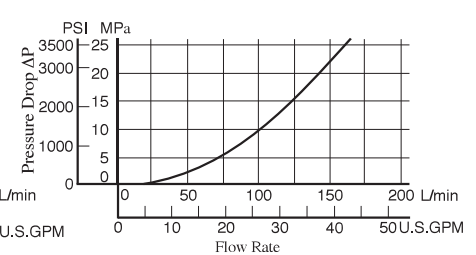

List of Seals

CPT/CPDT-03-**-50/5080/5090
 CPT/CPDT-06-**-50/5080/5090
 CPT/CPDT-10-**-50/5080/5090

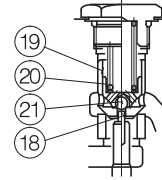
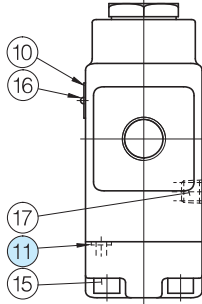
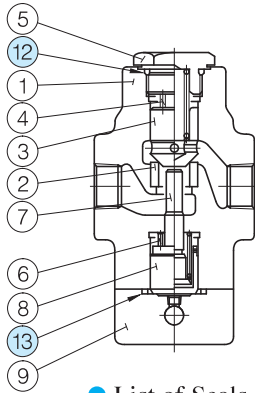

CPDT-03/06/10

List of Seals

Item	Name of Parts	Part Numbers			Qty.
		CPT/CPDT-03	CPT/CPDT-06	CPT/CPDT-10	
11	O-Ring	SO-NB-P7	SO-NB-P9	SO-NB-P9	1
12	O-Ring	SO-NB-P21	SO-NB-P29	SO-NB-P36	1
13	O-Ring	SO-NB-G25	SO-NB-P32	SO-NB-P42	1

Note: When ordering the seals, please specify the seal kit number from the table below.

CPG/CPDG-03-**-50/5090
 CPG/CPDG-06-**-50/5090
 CPG/CPDG-10-**-50/5090

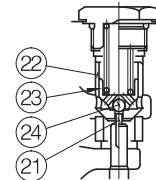
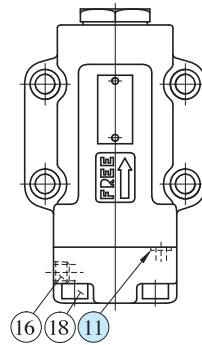
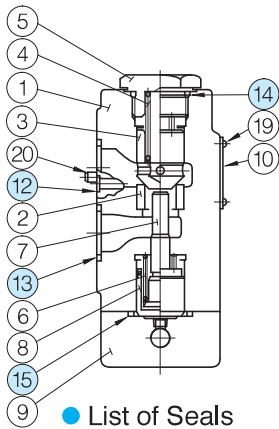

CPDG-03/06/10

List of Seals

Item	Name of Parts	Part Numbers			Qty.
		CPG/CPDG-03	CPG/CPDG-06	CPG/CPDG-10	
11	O-Ring	SO-NB-P7	SO-NB-P9	SO-NB-P9	1
12	O-Ring	SO-NB-P9	SO-NB-P9	SO-NB-P9	2
13	O-Ring	SO-NB-P18	SO-NB-P28	SO-NB-P32	2
14	O-Ring	SO-NB-P21	SO-NB-P29	SO-NB-P36	1
15	O-Ring	SO-NB-G25	SO-NB-P32	SO-NB-P42	1

Note: When ordering the O-Rings, please specify the seal kit number from the table below.

List of Seal Kits

Model Numbers	Seal Kit Numbers
CPT/CPDT-03-**-50/5080/5090	KS-CPT-03-50
CPT/CPDT-06-**-50/5080/5090	KS-CPT-06-50
CPT/CPDT-10-**-50/5080/5090	KS-CPT-10-50
CPG/CPDG-03-**-50/5090	KS-CPG-03-50
CPG/CPDG-06-**-50/5090	KS-CPG-06-50
CPG/CPDG-10-**-50/5090	KS-CPG-10-50